

TOP-1A

Specifications

Model	Item	Theoretical Displacement cm ³ /rev	Theoretical Discharge ℓ/min		Max. Discharge Pressure MPa	Max. Revolution min ⁻¹	Approx. Weight kg
			1500min ⁻¹	1800min ⁻¹			
TOP-10A		0.8	1.2	1.4	0.5	3000	0.5 (0.8)
TOP-11A		1.5	2.2	2.7	0.5	2000	0.5 (0.8)
TOP-12A		2.5	3.7	4.5	0.5	1800	0.6 (0.9)
TOP-13A		4.5	6.7	8.1	0.5	1800	0.8 (1.1)

The above maximum discharge and maximum revolution values are for when using ISO-VG46 oil with an oil temperature of 40 °C.
The approximate weight values shown in the brackets () are for when a relief valve is attached.

Model



TOP -

10A
11A
12A
13A

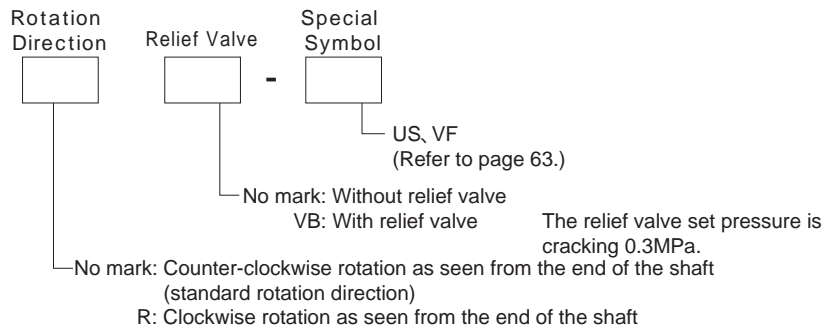

Model Examples:

TOP-10AVB (with relief valve)

TOP-11AR (clockwise rotation as seen from the end of the shaft)

Performance Table

Test Conditions Oil: ISO-VG46 with a temperature of 40 °C

At 1,450 Rotations

At 1,750 Rotations

Flow Rate Characteristics

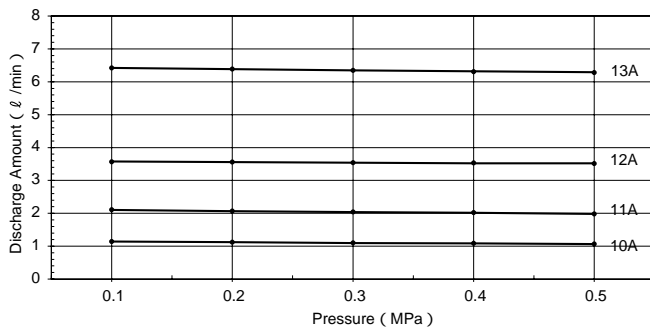

Flow Rate Characteristics

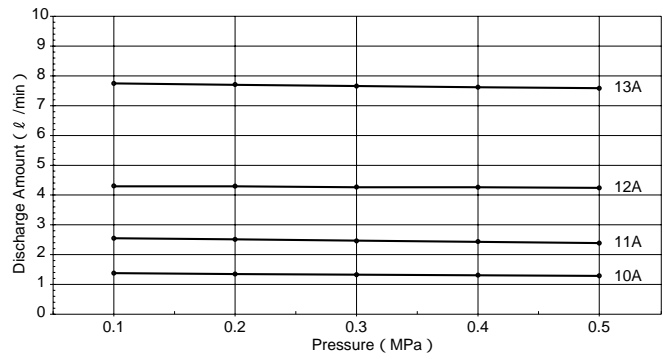

Required Power

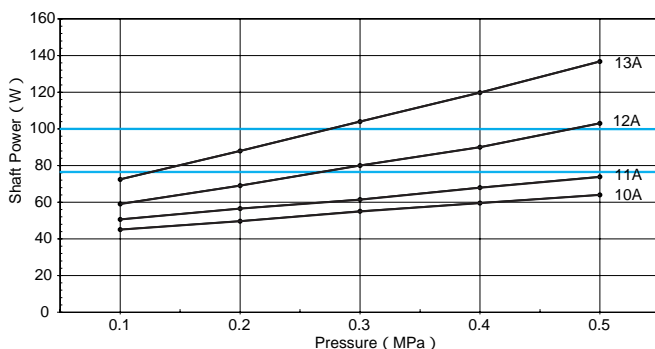

Required Power

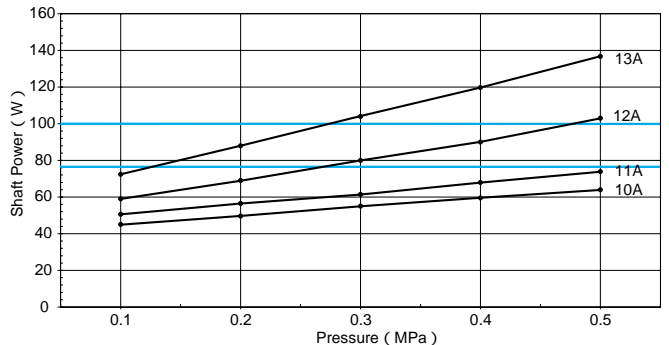

Select the best motor using the lines in the "Required Power" table as the applicable standards.

Dimensional Diagrams

Be sure to check the Nippon Oil Pump homepage for the most up-to-date diagrams and dimensions.

Model : TOP - 1 A

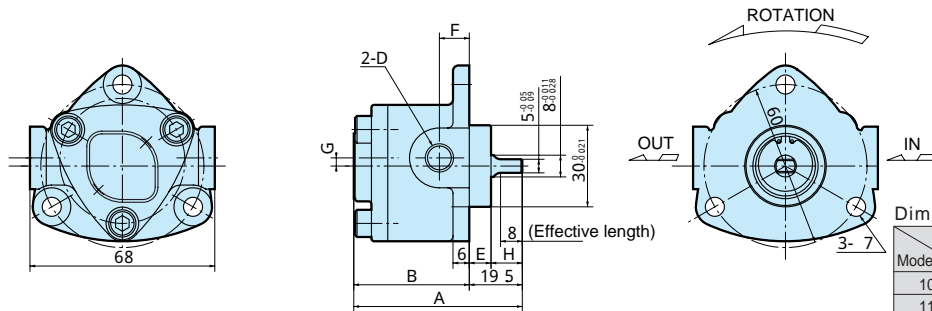

Dimensions

Item Model	A	B	D	E	F	G	H
10A	57	37.5	Rc ¹ / ₈	8	11	3	11.5
11A	57	37.5	Rc ¹ / ₈	8	11	3	11.5
12A	63	43.5	Rc ¹ / ₄	8	11	3	11.5
13A	78	58.5	Rc ³ / ₈	5	14	5.5	14.5

Model : TOP - 1 AVB

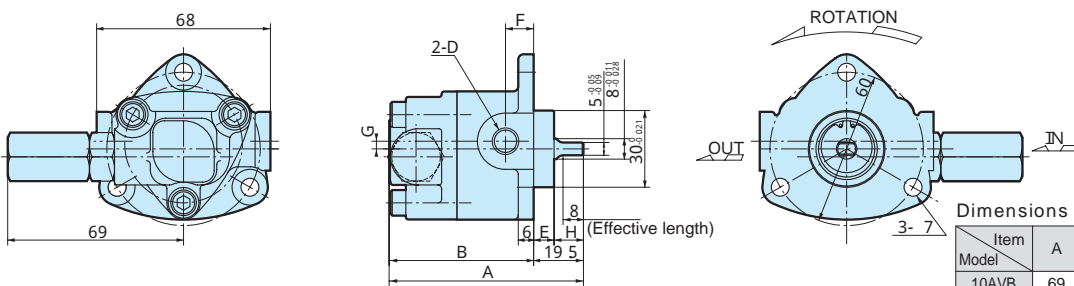

Dimensions

Item Model	A	B	D	E	F	G	H
10AVB	69	49.5	Rc ¹ / ₈	8	11	3	11.5
11AVB	69	49.5	Rc ¹ / ₈	8	11	3	11.5
12AVB	75	55.5	Rc ¹ / ₄	8	11	3	11.5
13AVB	90	70.5	Rc ³ / ₈	5	14	5.5	14.5

Model : TOP - 1 AR

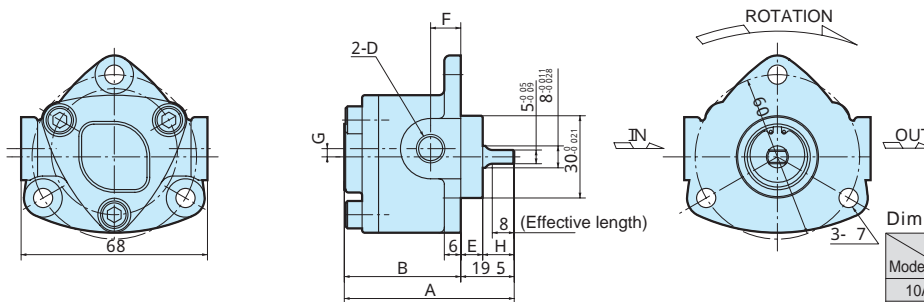

Dimensions

Item Model	A	B	D	E	F	G	H
10AR	57	37.5	Rc ¹ / ₈	8	11	3	11.5
11AR	57	37.5	Rc ¹ / ₈	8	11	3	11.5
12AR	63	43.5	Rc ¹ / ₄	8	11	3	11.5
13AR	78	58.5	Rc ³ / ₈	5	14	5.5	14.5

Model : TOP - 1 ARVB

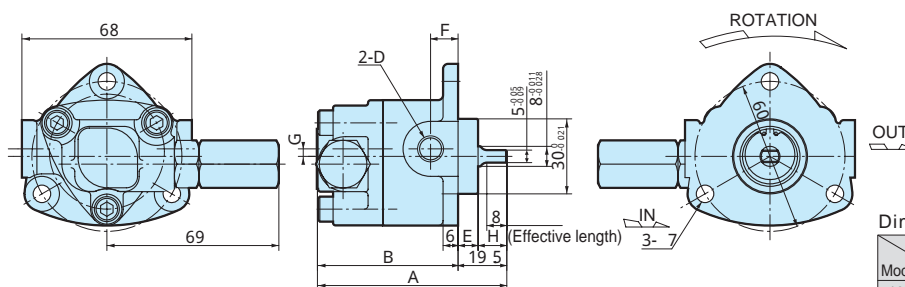

Dimensions

Item Model	A	B	D	E	F	G	H
10ARVB	69	49.5	Rc ¹ / ₈	8	11	3	11.5
11ARVB	69	49.5	Rc ¹ / ₈	8	11	3	11.5
12ARVB	75	55.5	Rc ¹ / ₄	8	11	3	11.5
13ARVB	90	70.5	Rc ³ / ₈	5	14	5.5	14.5